

DETAIL A

APPROVED FOR PRODUCTION  
 2017/8/17 RFL

REV 更改号	DATE 日期	REVISION DETAILS 更改内容	APPD 审核并批准
A	2017.7.10	PRODUCTION ISSUE	
B	Aug.4,2017	Drawing update as 45degree JIC in SAEJ513	

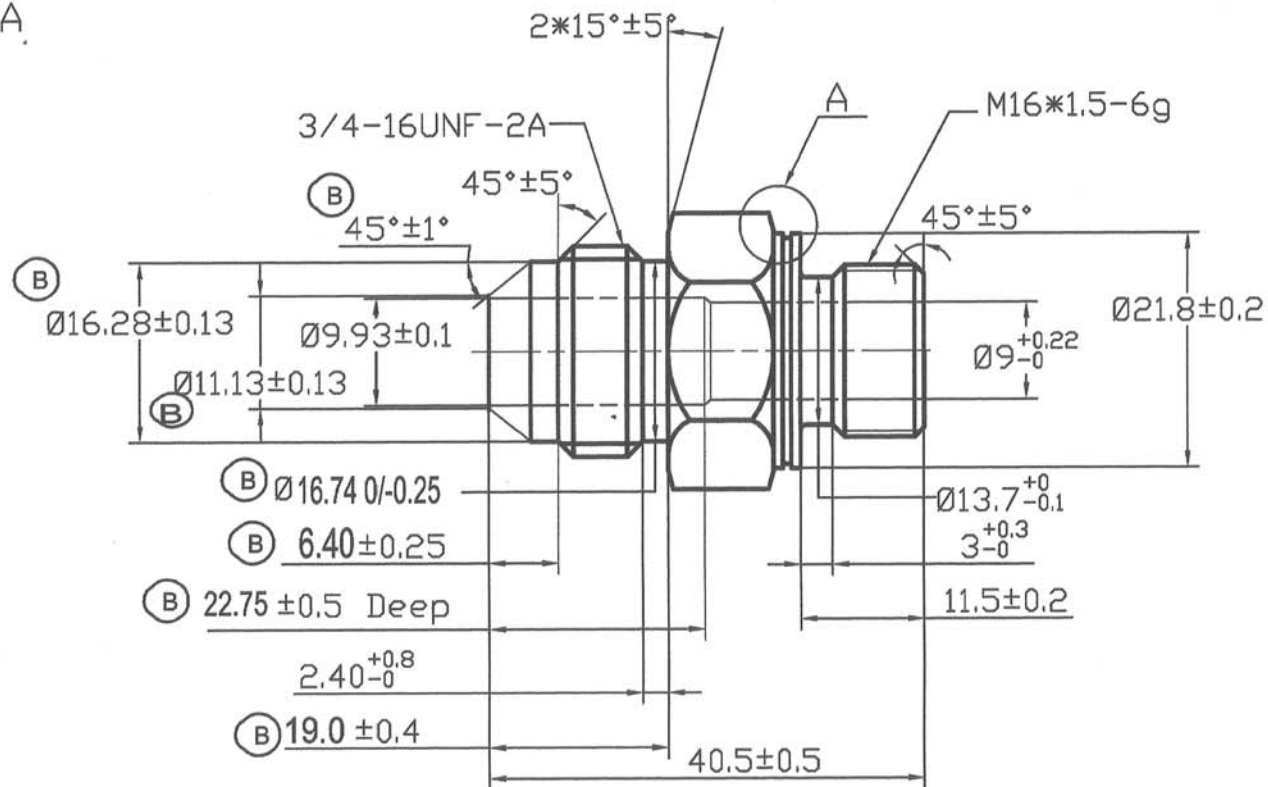

UNLESS SPECIFIED  
 ALL DIMENSIONS IN mm,  
 MACHINED SURFACES Ra=3.2um,  
 ANGLE TOLERANCES ±1°,  
 Other tolerance except angles,  
 in accordance with  
 GB/T1804-2000(ISO2768-1)-m and  
 GB/T1184-1996(ISO 2768-2)-m

其它事项  
 图示尺寸单位为MM  
 未注机加工表面粗糙度为Ra=3.2  
 未注角度公差±1°  
 其它未注公差（除角度外）均按：  
 GB/T1804-2000(ISO2768-1)-M和  
 GB/T1184-1996(ISO 2768-2)-m



PART NO 零件名	5-6400-8-M16
----------------	--------------

SCALE NTS	APPD: Zhang 批准: <del>David</del>	DRN 制图: KEVIN	DATE 日期: 2017.07.10
	DATE 日期: 07/08/17	CHK 审核: YB. ZHAN 材质: 45#	DATE 日期: 2017.07.10

MATERIAL	CHINA 45#	材质: 45#
FINISH	Remove all sharp edges, burns, slivers and swarf, break all edges 0.127-0.254mm. zinc plating with 12um microns minimum plating thickness and trivalent chromate passivation and withstand 96 HRS to white/144 HS to red rust in salt spray test.	去除所有毛刺, 铁销等残留物, 锐边倒钝0.127-0.254MM 镀锌, 三价铬钝化, 银白色, 中国标准GB/T 9001-2008 144小时无红锈, 镀锌层厚度大于12um.